



Chronological Storying of the Bible

Introductory Workshop



Chronological Storying
of the Bible
What have you heard?
Introductory Workshop

Part One: Issues

- Hearing--Understanding & Retention
- Illiteracy
- Adjusting
- Learning Preferences--Grid

Lyticerl

- Gureifs io Lyticerl--@%-#)5 *ot flochik*
- IPX (%5 *ot lajmittic*
- &)5 ih ^)5 mott
- Pe Lome, Buytl & Triff (ertoping)

Literacy

- Figures on Literacy--25-30% *if truthful*
- USA 95% *if accurate*
- 70% or 60% less
- Of Image, Voting & Loans (reasons)

Illiteracy Rates

Hong Kong	25%	Senegal	90%
Venezuela	14%	Colombia	20%
Italy	7%	Cyprus	1%
Guatemala	50%	Egypt	60%
China	25%	Nigeria	70%
Philippines	12%	Ecuador	10%
Thailand	18%	Taiwan (China)	6%
Brazil	24%	Bolivia	37%
Spain	3%		
Caribbean Islands	40% (St. Lucia) - 11% (Trinidad & Tobago)		
	5% (Netherlands Antilles)		

The Basics of Storying

Storying is chosen
because it is a

?????

???????????

vehicle of the
target people.



The Basics of Storying

Storying is chosen
because it is a
primary
communication

vehicle of the
target people.



The Basics of Storying

Storying is based
entirely upon the
????



The Basics of Storying

Storying is based
entirely upon the
Bible.



The Basics of Storying

Storying is chronological,
s - e - q - u - e - n - t - i - a - l.

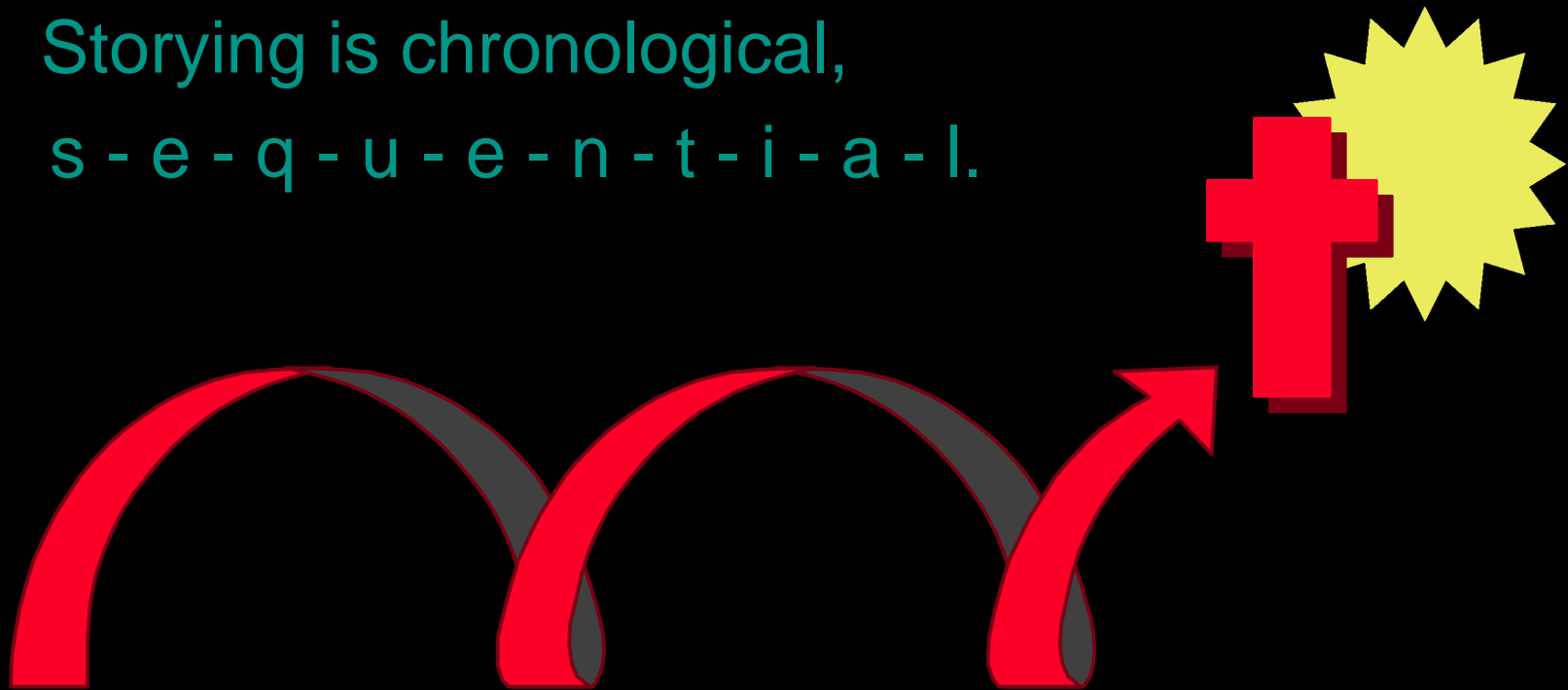

The Basics of Storying

Storying looks
backward, but never
???????



The Basics of Storying

Storying looks
backward, but never
forward.
(jumping ahead)

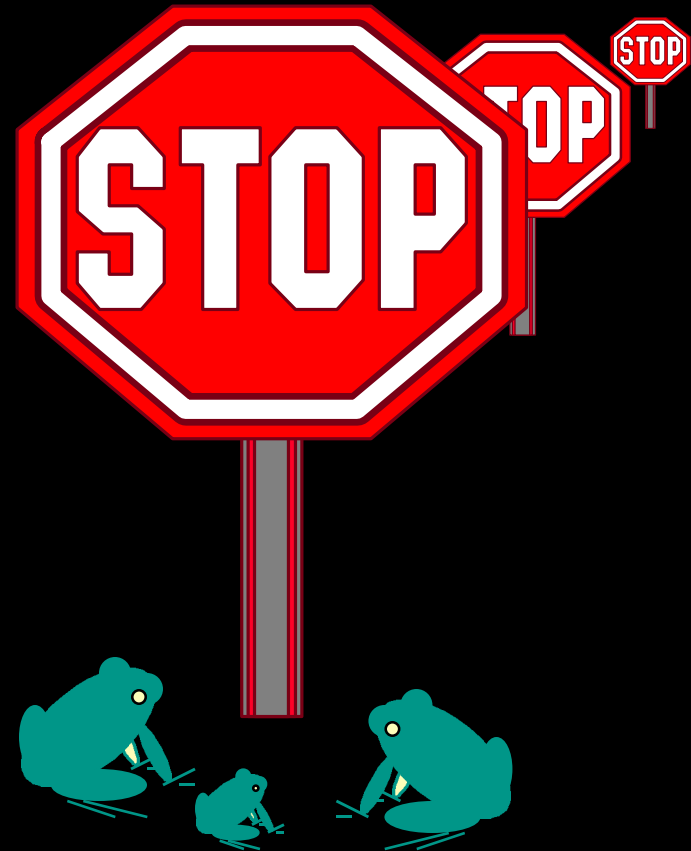

The Basics of Storying

Stories are chosen based upon the universal biblical truths to be communicated.



The Basics of Storying

Stories are chosen based upon identified ??????? and ??????? in the target people's ???????

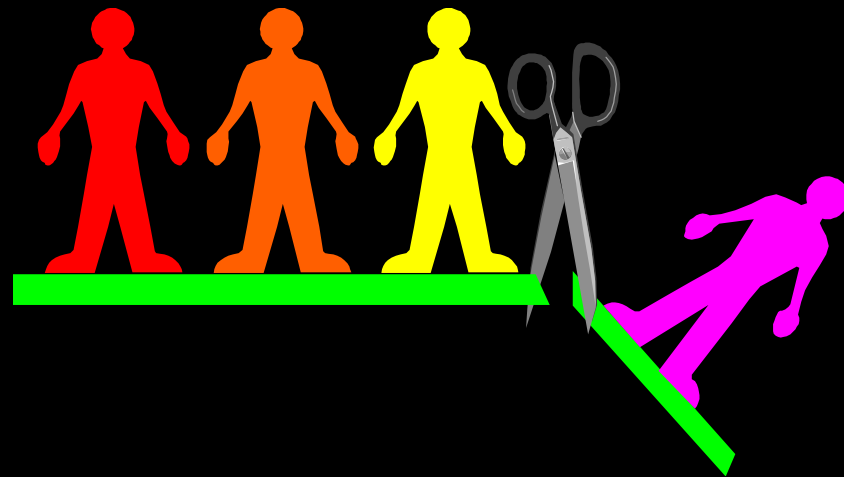

The Basics of Storying

Stories are chosen based upon identified bridges and barriers in the target people's worldview.

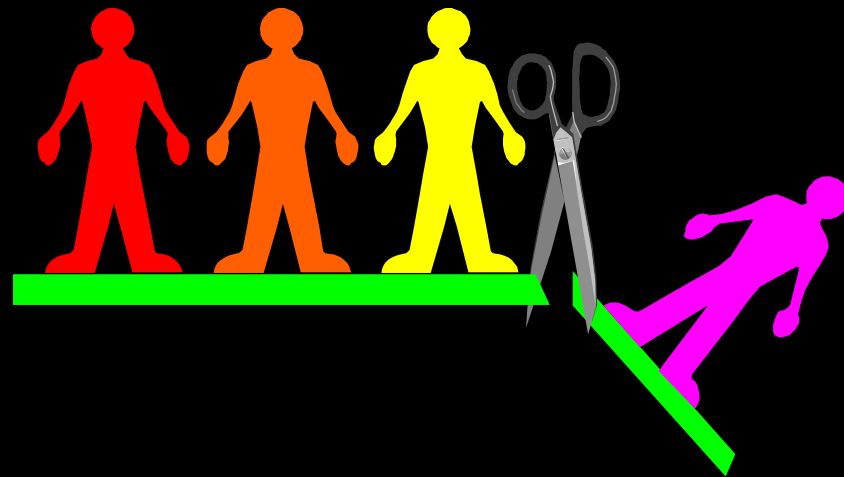

The Basics of Storying

Storying is structured to give an *oral Bible* to individuals and to develop the competency to share it *orally*.



The Basics of Storying

Storying is a “win/win” approach until the story of the crucifixion and resurrection when the major invitation is given.



The Basics of Storying

Storying is
predominately
narrative with
minimal exposition.

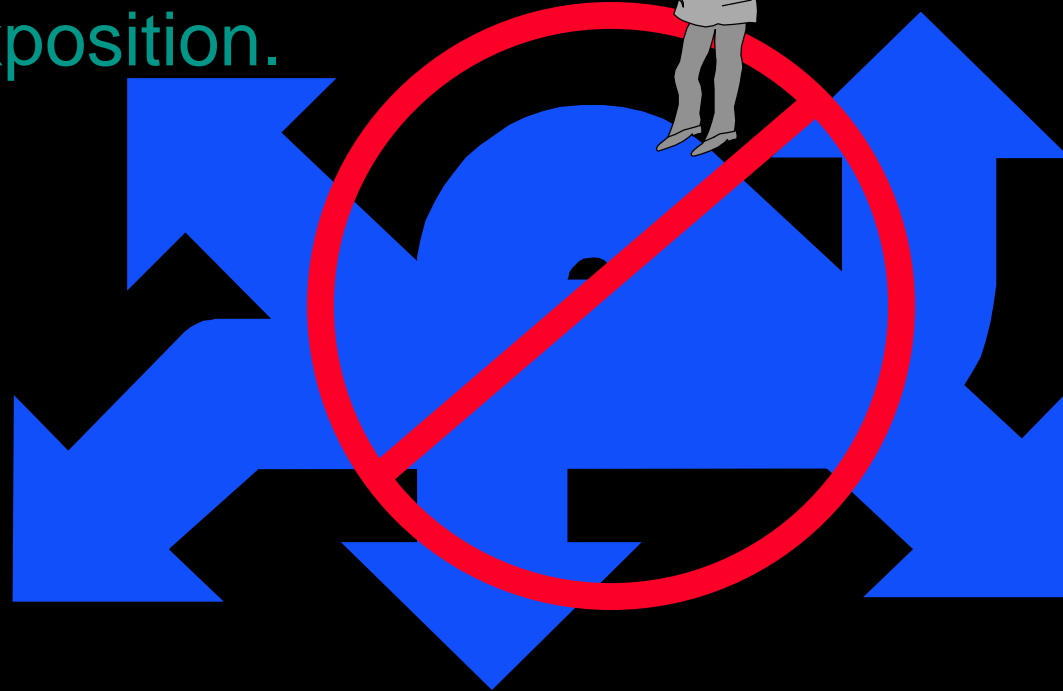

The Basics of Storying

Storying is
predominately
narrative with
minimal exposition.



A decorative border on the left and right sides of the slide, consisting of a vertical sequence of diagonal stripes in red, blue, teal, orange, and yellow colors.

“EETAOW!”
Video Case Study
from
New Tribes Mission

Segmentation of Society from Perspective of Literacy

- A

Learns only by oral tradition

Not mobile except when group is nomadic

Most often rural people

If in urban area, lives in illiterate pocket

Culturally relational

Tribal dress & lifestyle

Usually poor

Animistic or animistic beneath world religion or folk religionist

Wholistic view of world and life

Segmentation of Society from Perspective of Literacy

- A

Oral tradition
Not mobile
Rural
Urban/Illiterate
Relational
Tribal
Poor
Animistic
Wholistic view

- B

Classified as literate at times
Functionally illiterate
Mobile only in occupation
Occupationally adapts to urban or western styles
Tribal focus and orientation
Aware of and does business with literate, word-culture people
Learns primarily by oral tradition
Culturally relational
Usually tribally dressed

Segmentation of Society from Perspective of Literacy

• A

Oral tradition
Not mobile
Rural
Urban/Illiterate
Relational
Tribal
Poor
Animistic
Wholistic view

• B

At times literate
Funct. illiterate
Mobile at job
Western on job
Does business with literates
Oral tradition
Relational
Usually tribally dressed

• C

Literate
Clerical, Sales & Service
Works in literate world
Mobile or semi-mobile
Semi-westernized dress/life
Becoming Detribalized
Lives in "tribal" community
Often urbanized
Becoming literate
Learns by literate & oral
Becoming individualistic
May be religious & materialistic mixed

Segmentation of Society from Perspective of Literacy

• A

Oral tradition
Not mobile
Rural
Urban/Illiterate
Relational
Tribal
Poor
Animistic
Wholistic view

• B

At times literate
Funct. illiterate
Mobile at job
Western on job
Does business with literates
Oral tradition
Relational
Usually tribally dressed

• C

Literate
Works in literate world
Mobile
Semi-westernized
Becoming Detribalized
“Tribal” community
Often urbanized
Becoming literate
Literate & oral
Becoming individual
Mixed religion

• D

Literate
Professional
Mobile
Westernized
Detribalized
Analytical
Logical
Often Urban
Literate
Individualist
Materialistic
Religion weak

Segmentation of Society from Perspective of Literacy

The Impact of **CHRISTIANITY & EDUCATION**
in **AFRICA** from 1600-1990

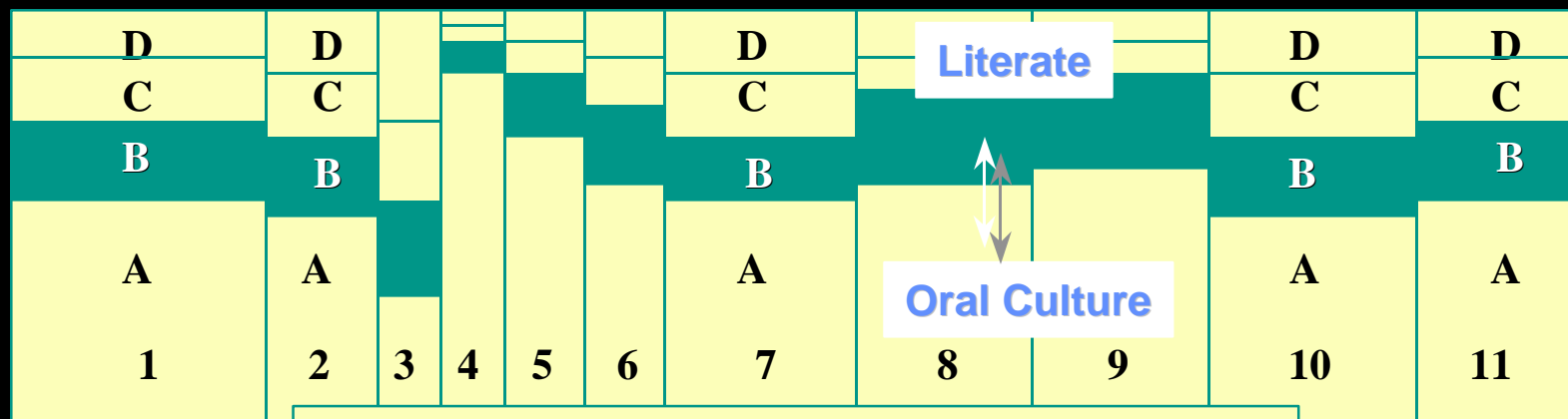

An illustration from eleven sampled language groups

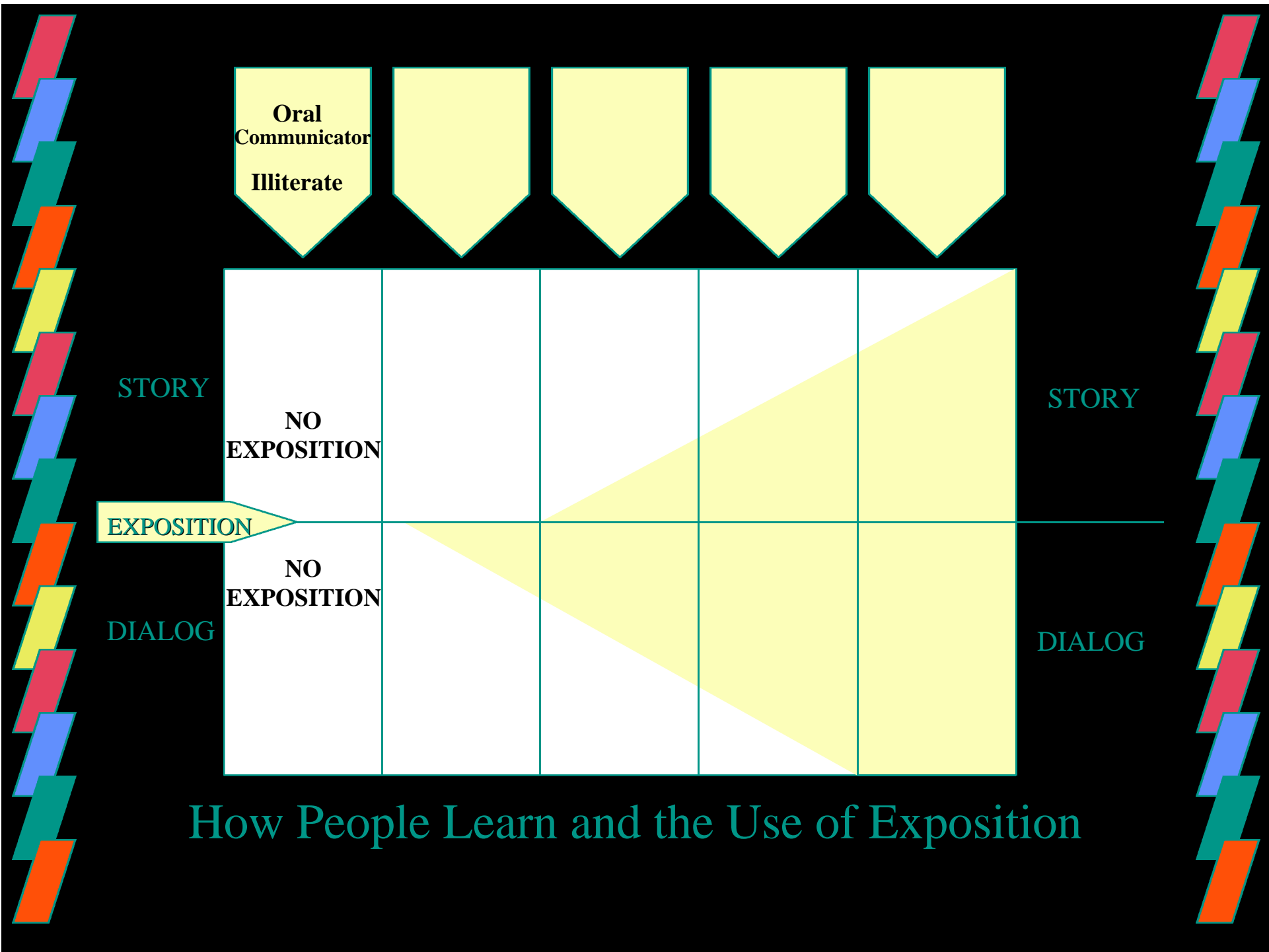

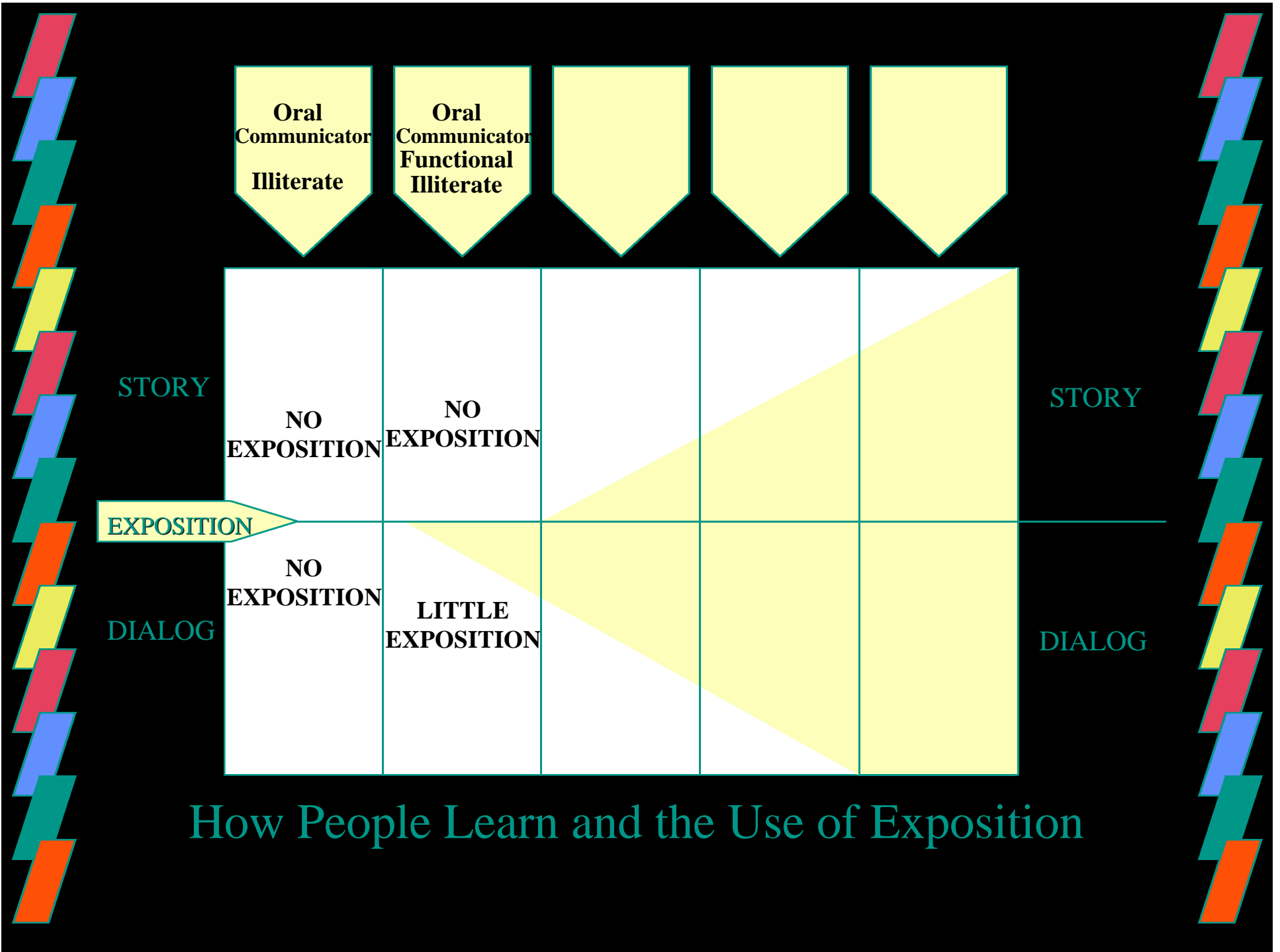

How People Learn and the Use of Exposition

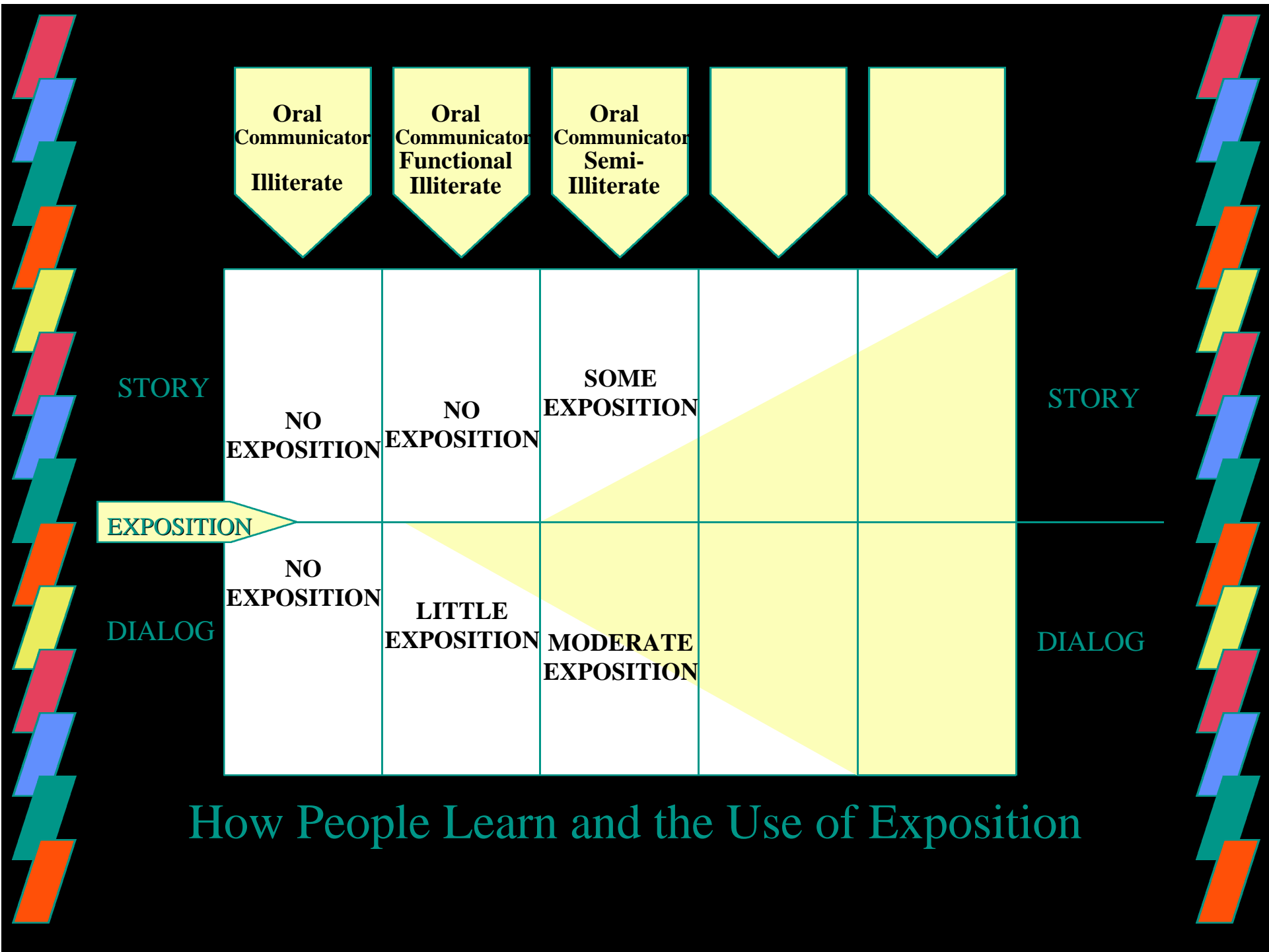

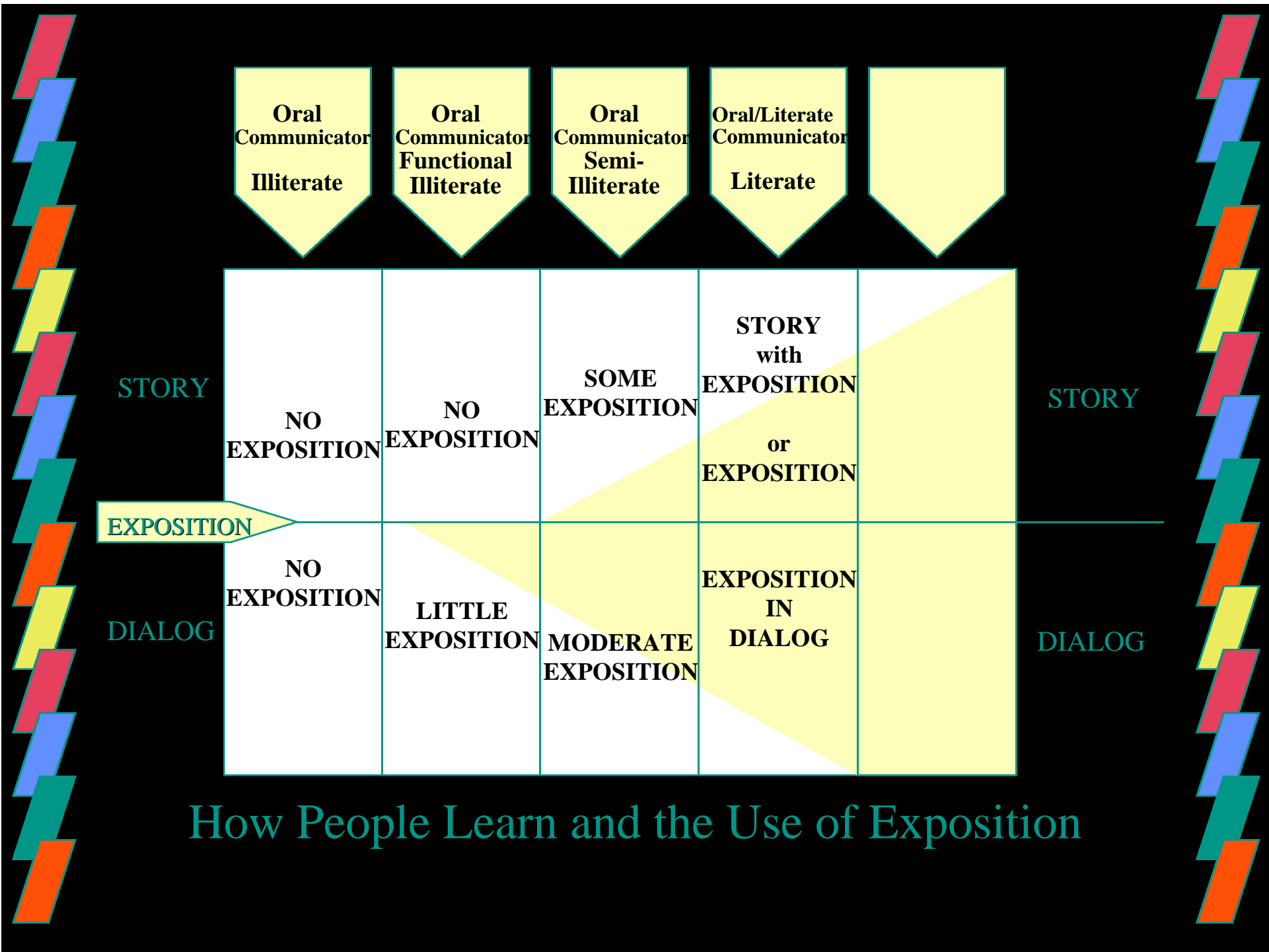

	Oral Communicator Illiterate	Oral Communicator Functional Illiterate	Oral Communicator Semi-Illiterate	Oral/Literate Communicator Literate	Literate Communicator Highly Literate
STORY	NO EXPOSITION	NO EXPOSITION	SOME EXPOSITION	STORY with EXPOSITION or EXPOSITION	NO STORY or STORIES with as MUCH EXPOSITION as needed
DIALOG	NO EXPOSITION	LITTLE EXPOSITION	MODERATE EXPOSITION	EXPOSITION IN DIALOG	as MUCH EXPOSITION as desired or interest calls for

How People Learn and the Use of Exposition



Step Two: Process

- Introduction to the “Lome Y”
 - Worldview Development
 - Selecting Stories
 - Storying
 - Problem Shooting
- 

CHRONOLOGICAL STORYING PROCESS

Church PLANTING Phase

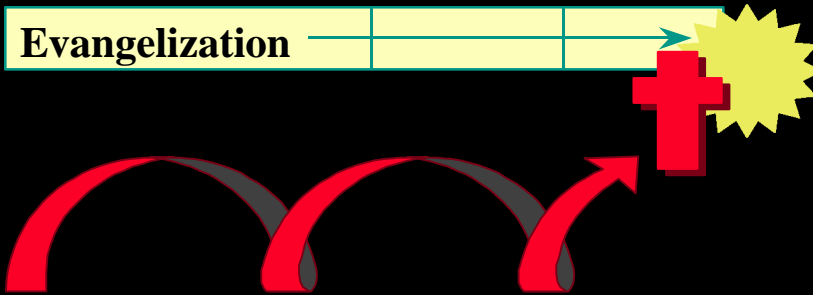

CHRONOLOGICAL STORYING PROCESS

Church PLANTING Phase

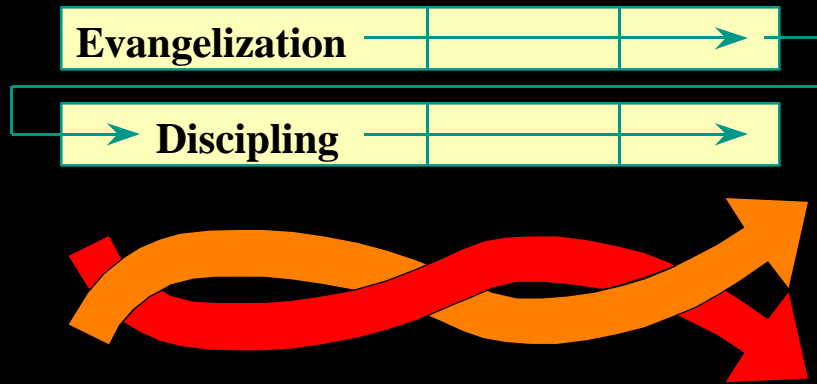

CHRONOLOGICAL STORYING PROCESS

Church PLANTING Phase

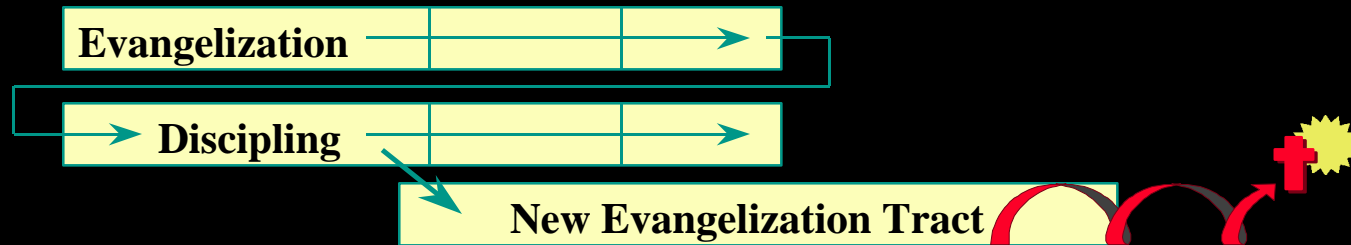

CHRONOLOGICAL STORYING PROCESS

Church PLANTING Phase

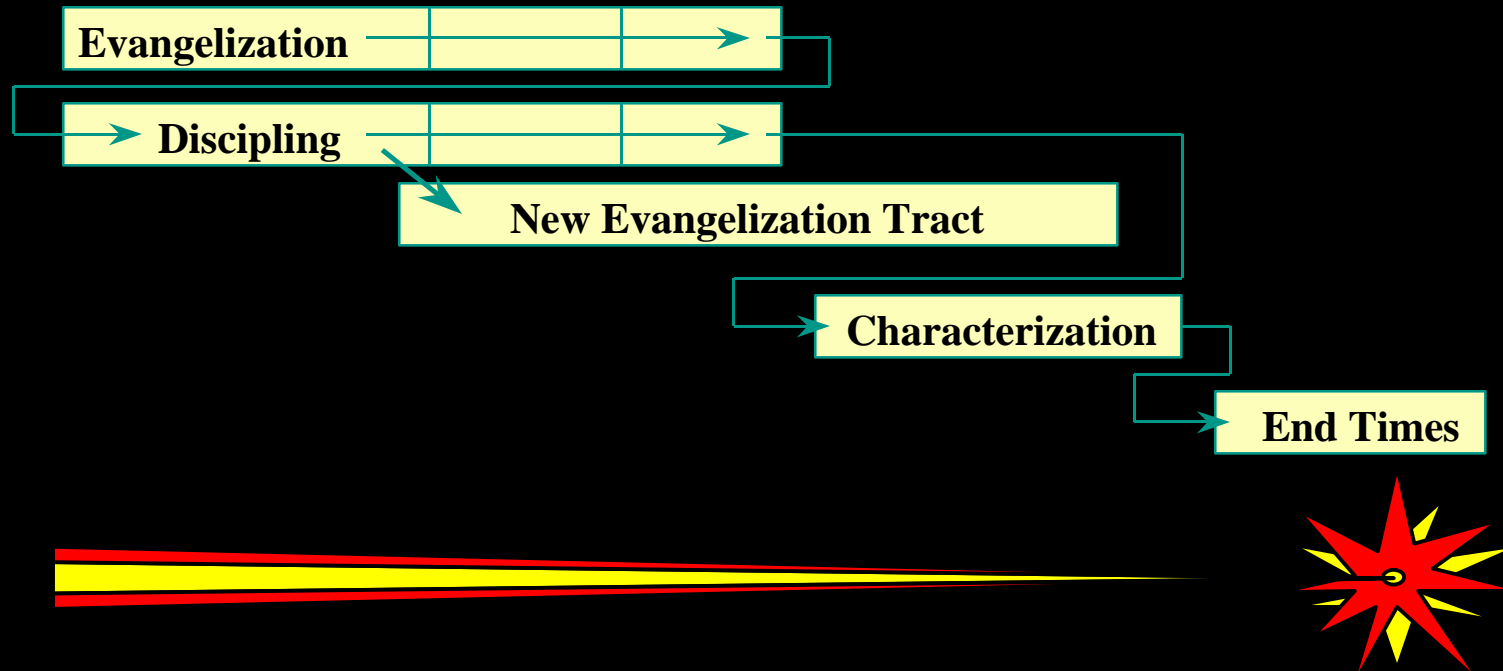

CHRONOLOGICAL STORYING PROCESS

Church STRENGTHENING Phase



The Lome Y

Worldview
Spiritual Barriers & Bridges
Perceived Needs

LANGUAGE &
CULTURE

LOSTNESS OF MAN

Foundational
& Essential
Truths for Salvation



The Lome Y

Worldview
Spiritual Barriers & Bridges
Perceived Needs

LANGUAGE &
CULTURE

LOSTNESS OF MAN

Foundational
& Essential
Truths for Salvation

STORY SELECTION
CRITERIA
10-15 Maximum



The Lome Y

Worldview
Spiritual Barriers & Bridges
Perceived Needs

LANGUAGE &
CULTURE

LOSTNESS OF MAN

Foundational
& Essential
Truths for Salvation

STORY SELECTION
CRITERIA
10-15 Maximum

→ EXAMINE
BIBLE STORY LIST ←



The Lome Y

Worldview
Spiritual Barriers & Bridges
Perceived Needs

LANGUAGE &
CULTURE

LOSTNESS OF MAN

Foundational
& Essential
Truths for Salvation

STORY SELECTION
CRITERIA
10-15 Maximum

→ EXAMINE
BIBLE STORY LIST ←

→ SELECT
TRIAL STORY SET ←



The Lome Y

Worldview
Spiritual Barriers & Bridges
Perceived Needs

LANGUAGE &
CULTURE

LOSTNESS OF MAN

Foundational
& Essential
Truths for Salvation

STORY SELECTION
CRITERIA
10-15 Maximum

EXAMINE
BIBLE STORY LIST

SELECT
TRIAL STORY SET

Helps
Stories



PREPARE
STORY LESSONS

←
← Review
Dialog



The Lome Y

Worldview
Spiritual Barriers & Bridges
Perceived Needs

LANGUAGE &
CULTURE

LOSTNESS OF MAN

Foundational
& Essential
Truths for Salvation

STORY SELECTION
CRITERIA
10-15 Maximum

EXAMINE
BIBLE STORY LIST

SELECT
TRIAL STORY SET

Helps
Stories

PREPARE
STORY LESSONS

Review
Dialog

TEST SET & LESSONS

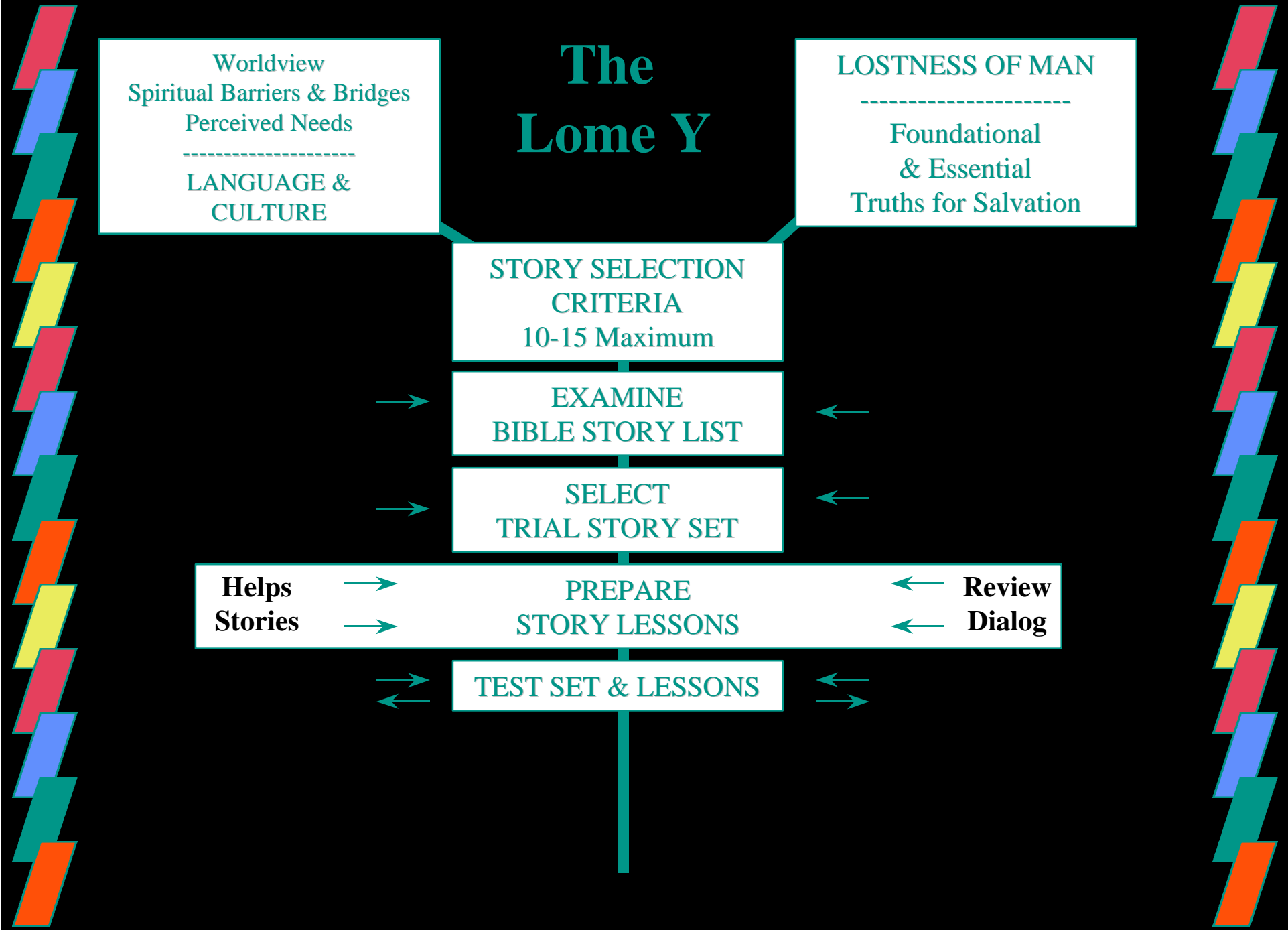

The Lome Y

Worldview
Spiritual Barriers & Bridges
Perceived Needs

LANGUAGE &
CULTURE

LOSTNESS OF MAN

Foundational
& Essential
Truths for Salvation

STORY SELECTION
CRITERIA
10-15 Maximum

EXAMINE
BIBLE STORY LIST

SELECT
TRIAL STORY SET

Helps
Stories

PREPARE
STORY LESSONS

Review
Dialog

TEST SET & LESSONS

ADJUST LIST
ADD OR DELETE

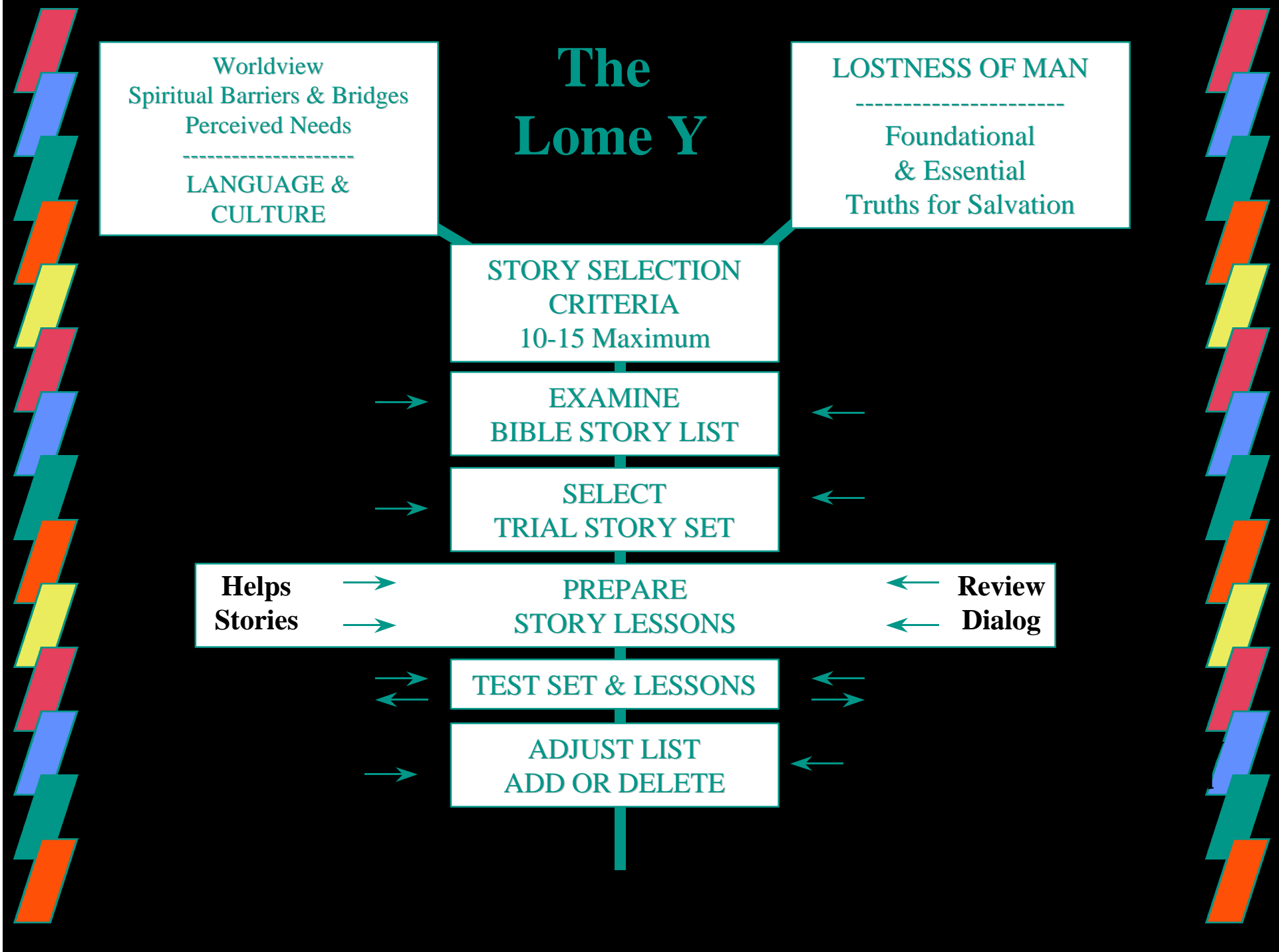

The Lome Y

Worldview
Spiritual Barriers & Bridges
Perceived Needs

LANGUAGE &
CULTURE

LOSTNESS OF MAN

Foundational
& Essential
Truths for Salvation

STORY SELECTION
CRITERIA
10-15 Maximum

EXAMINE
BIBLE STORY LIST

SELECT
TRIAL STORY SET

Helps
Stories

PREPARE
STORY LESSONS

Review
Dialog

TEST SET & LESSONS

ADJUST LIST
ADD OR DELETE

MODEL STORY
& LESSON SET

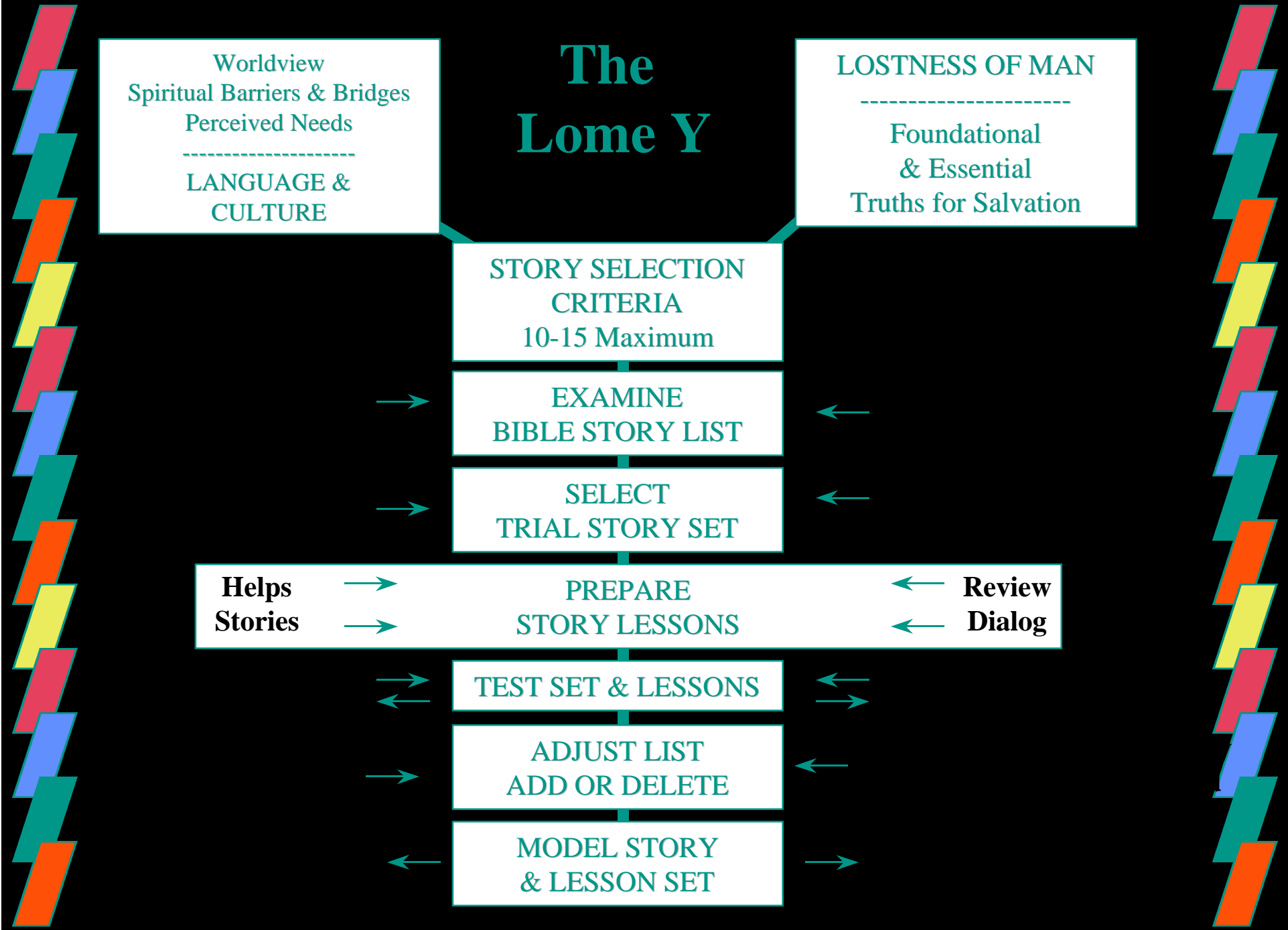



The
Ponderosa
Pyramid

A flow chart of:
Storying the Bible
Chronologically

**Determine my understanding
of the essentials of the Gospel in light of the universal needs of humanity**



The
Ponderosa
Pyramid

A flow chart of:
Storying the Bible
Chronologically

**Delineate the insights obtained through
internalizing the target population's language and worldview**

**Determine my understanding
of the essentials of the Gospel in light of the universal needs of humanity**



The
Ponderosa
Pyramid

A flow chart of:
Storying the Bible
Chronologically

**Discover similarities and
barriers between their worldview and the gospel**

**Delineate the insights obtained through
internalizing the target population's language and worldview**

**Determine my understanding
of the essentials of the Gospel in light of the universal needs of humanity**



The
Ponderosa
Pyramid

A flow chart of:
Storying the Bible
Chronologically

**Develop objectives for presenting
the Gospel in the context of their needs**

**Discover similarities and
barriers between their worldview and the gospel**

**Delineate the insights obtained through
internalizing the target population's language and worldview**

**Determine my understanding
of the essentials of the Gospel in light of the universal needs of humanity**



The
Ponderosa
Pyramid

A flow chart of:
Storying the Bible
Chronologically



**Design a set of
themes for the storying process**

**Develop objectives for presenting
the Gospel in the context of their needs**

**Discover similarities and
barriers between their worldview and the gospel**

**Delineate the insights obtained through
internalizing the target population's language and worldview**

**Determine my understanding
of the essentials of the Gospel in light of the universal needs of humanity**

The
Ponderosa
Pyramid

A flow chart of:
Storying the Bible
Chronologically

**Decide which
stories carry the themes**

**Design a set of
themes for the storying process**

**Develop objectives for presenting
the Gospel in the context of their needs**

**Discover similarities and
barriers between their worldview and the gospel**

**Delineate the insights obtained through
internalizing the target population's language and worldview**

**Determine my understanding
of the essentials of the Gospel in light of the universal needs of humanity**

Story

**Do preparation of
logistics, story
lessons & pre-testing**

**Decide which
stories carry the themes**

**Design a set of
themes for the storying process**

**Develop objectives for presenting
the Gospel in the context of their needs**

**Discover similarities and
barriers between their worldview and the gospel**

**Delineate the insights obtained through
internalizing the target population's language and worldview**

**Determine my understanding
of the essentials of the Gospel in light of the universal needs of humanity**

The
Ponderosa
Pyramid

A flow chart of:
Storying the Bible
Chronologically

Worldview Development Definition

“Worldview”

- Profile of the way people
 - live
 - act
 - think
 - work
 - relate
- within a specific culture.

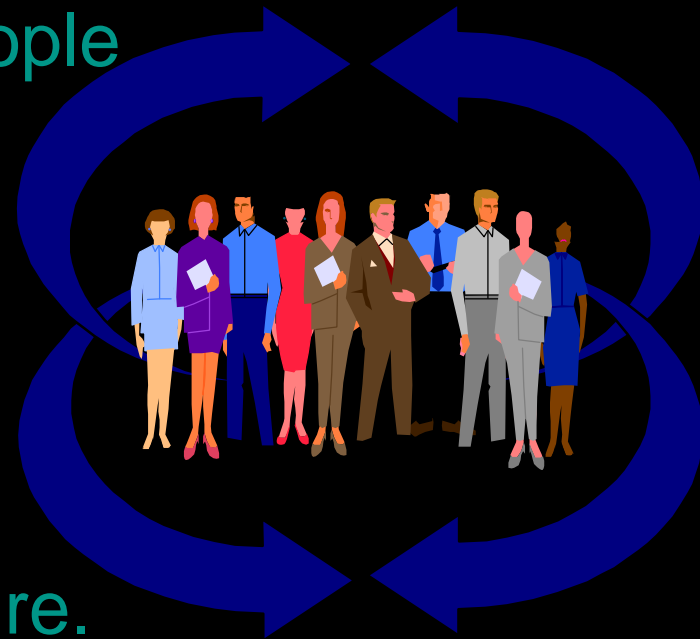

Worldview Development

Why?



- 1 Foundation to understanding
- 2 Contrasts (especially with Christianity)
- 3 Major issues
- 4 Barriers & bridges to the gospel
- 5 Basis for biblical doctrine & lesson objectives
- 6 Themes, issues & story selection
- 7 Understand gospel implications
- 8 Learning scale & gospel receptivity scale
- 9 Avoid syncretism

Worldview Development Steps



- 1 Research
- 2 Map
- 3 Demographic Information
- 4 Conduct Study
- 5 Worldview Document (people profile)
- 6 Christianity Comparison
- 7 Consider other issues including these categories:
 - Life Cycle
 - Household Habits
 - Instructions to Kids
 - The Supernatural
 - Forms of Ritual
 - Cultural Structures, etc.

Worldview Development Analysis & Response



	Worldview Issue	Barrier?	Bridge?	Doctrinal Teaching
1.				
2.				
3.				
4.				
5.				

Worldview Development Analysis & Response



Worldview Issue	Barrier?	Bridge?	Doctrinal Teaching
1.	Ignorance		
	Apathy		
2.	Cultural Tradition		
3.	Former Beliefs & Practices		
	Other Religious Teachings		
4.	Nominalism		
5.	Fear of Persecution		
	Fear of Losing Material & Social Benefits		
	Fear of Disturbing Community Harmony		
	Fear of Disturbing Spirit World		
	Misinformation about Christianity, Biases		

Worldview Development Analysis & Response



Worldview Issue	Barrier?	Bridge?	Doctrinal Teaching
1.		Dreams	
2.		Brokenness	
3.		Testimonies	
4.		Cultural Stories	
5.		Relief Need	
		Moral or Spiritual Desire	
		Media Exposure	
		Curiosity	
		Prior Knowledge of God, Jesus, Christianity	
		Other Analogies	



Basic Christian Doctrines Necessary for Salvation

- 1 God acts in history and communicates with man.
 - 2 God is all powerful, all knowing, sovereign.
 - 3 God is faithful to His word.
 - 4 God loves man and wants fellowship with him.
 - 5 God hates sin.
 - 6 God punishes sin by death (separation from God).
 - 7 Man is accountable to God.
 - 8 Man is a sinner separated from God.
 - 9 Man can do nothing to save himself.
- 



Basic Christian Doctrines Necessary for Salvation

- 1 God acts in history and communicates with man.
 - 2 God is all powerful, all knowing, sovereign.
 - 3 God is faithful to His word.
 - 4 God loves man and wants fellowship with him.
 - 5 God hates sin.
 - 6 God punishes sin by death (separation from God).
 - 7 Man is accountable to God.
 - 8 Man is a sinner separated from God.
 - 9 Man can do nothing to save himself.
 - 10 Man can approach (have fellowship with) God only through a perfect (acceptable sacrifice. This involves faith and trust in God.
- 

Basic Christian Doctrines Necessary for Salvation

- 1 God acts in history and communicates with man.
- 2 God is all powerful, all knowing, sovereign.
- 3 God is faithful to His word.
- 4 God loves man and wants fellowship with him.
- 5 God hates sin.
- 6 God punishes sin by death (separation from God).
- 7 Man is accountable to God.
- 8 Man is a sinner separated from God.
- 9 Man can do nothing to save himself.
- 10 Man can approach (have fellowship with) God only through a perfect (acceptable sacrifice. This involves faith and trust in God.
- 11 Jesus the Son of God is the only perfect sacrifice.

Story Preparation

- Worldview Document
- Christian Doctrines
- Bridges & Barriers Stories
- Chronological Story/Topic List
- Review & Refine Story List
- Prepare Lessons
- Agree on a Meeting Time & Place
- Give Thought to Potential Interruptions in Schedule
- Prepare Objectives for Each Track According to the Strategy

Story Preparation

- On-course
Check & Bible
Study

Do your homework!



Story Preparation

- Previous Lesson Recall Questions

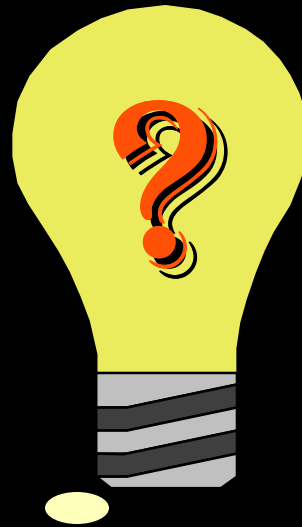

Story Preparation

- Memorize Story (Practice)

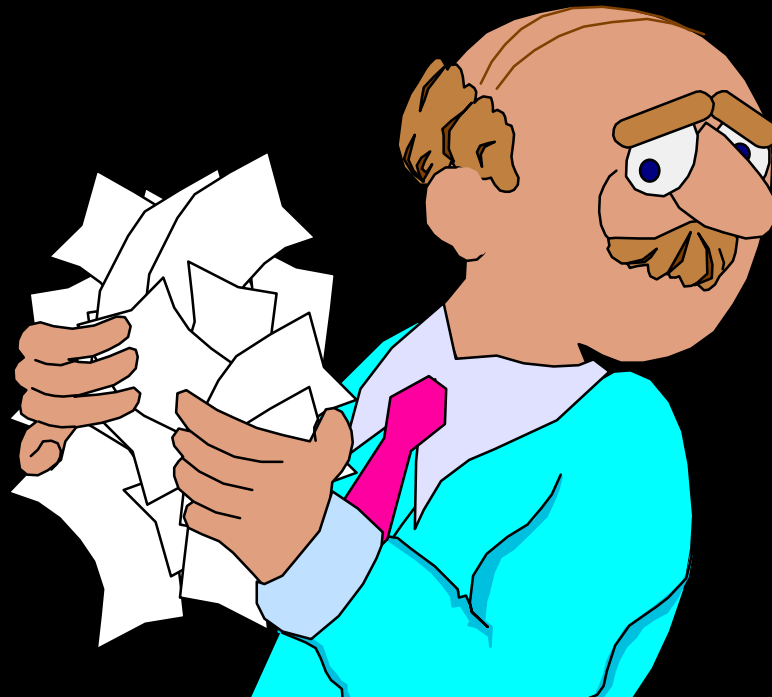

Uh-oh...

Story Preparation

- Know **what** should be learned

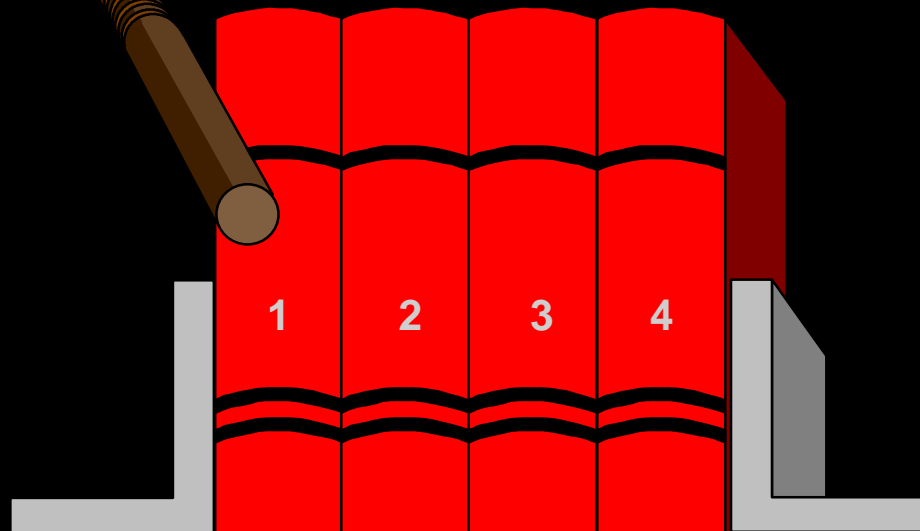

The Lome Y

Worldview
Spiritual Barriers & Bridges
Perceived Needs

LANGUAGE &
CULTURE

LOSTNESS OF MAN

Foundational
& Essential
Truths for Salvation

Don't forget!

STORY SELECTION
CRITERIA
10-15 Maximum

EXAMINE
BIBLE STORY LIST

SELECT
TRIAL STORY SET

Helps
Stories

PREPARE
STORY LESSONS

Review
Dialog

TEST SET & LESSONS

ADJUST LIST
ADD OR DELETE

MODEL STORY
& LESSON SET

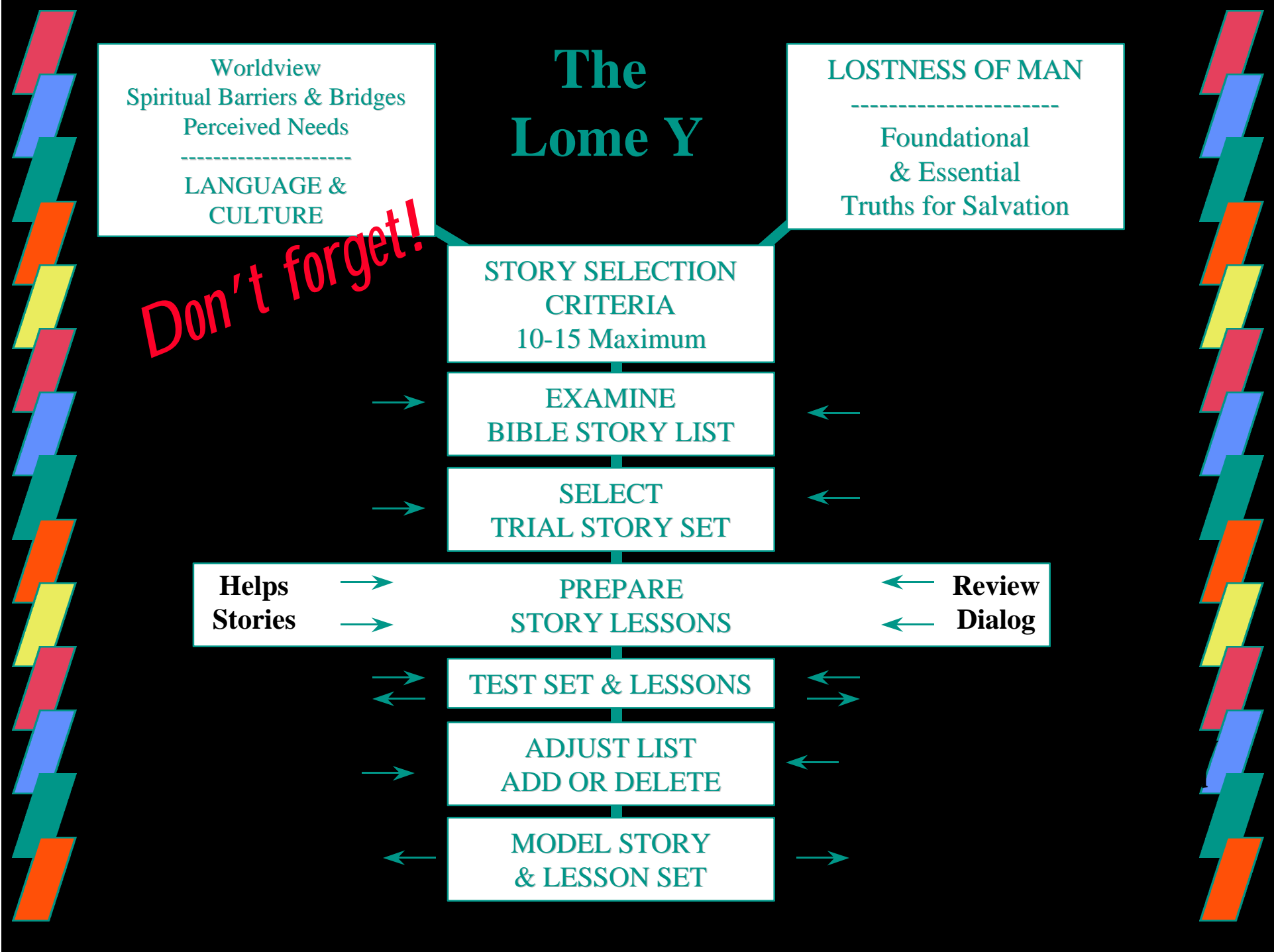

Storying

① Opening Dialog

- Greetings
- Singing?
- Recall
- Review/Explain
- Listening task



Storying

② Read from the Bible

- Hold the Bible
- Read portion
- Bible placement

Note: Muslim cultures may require the storyer not to use a Bible until later in the process.



Storying

- ③ Tell the Story
 - Story the Story
 - Don't read
 - Summaries
 - Simple Sentences
 - Accurate, but interesting
 - STOP at the end

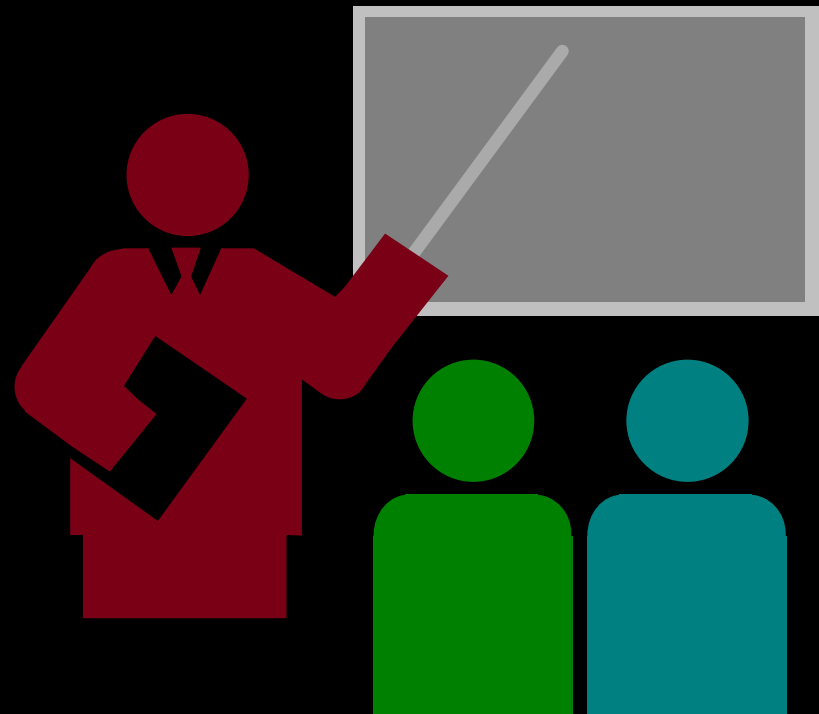

Storying

④ Dialog

- Story Truths
- Test comprehension
- Ask questions
- Sensitivities
- Encourage re-telling
- Do not rush



Problem Shooting

Internal

- Mix of believers/unbelievers
- Communication quirks of presenter
- “Hardness of Heart”
- Surprise Barriers
- Hostility & other group dynamics
- Evidence of falling away

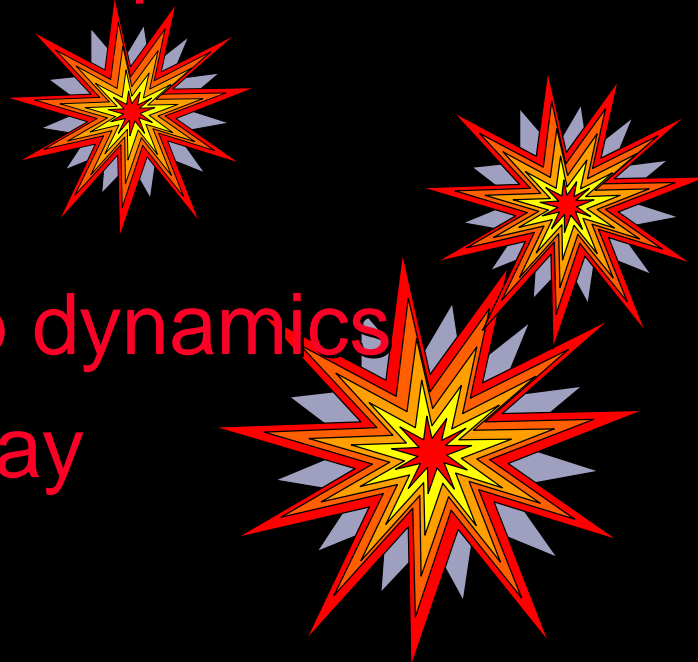

Problem Shooting

External

- Interruptions
- Poor location choice
- Schedule breaks
- Special Events
- Interference by other religious groups

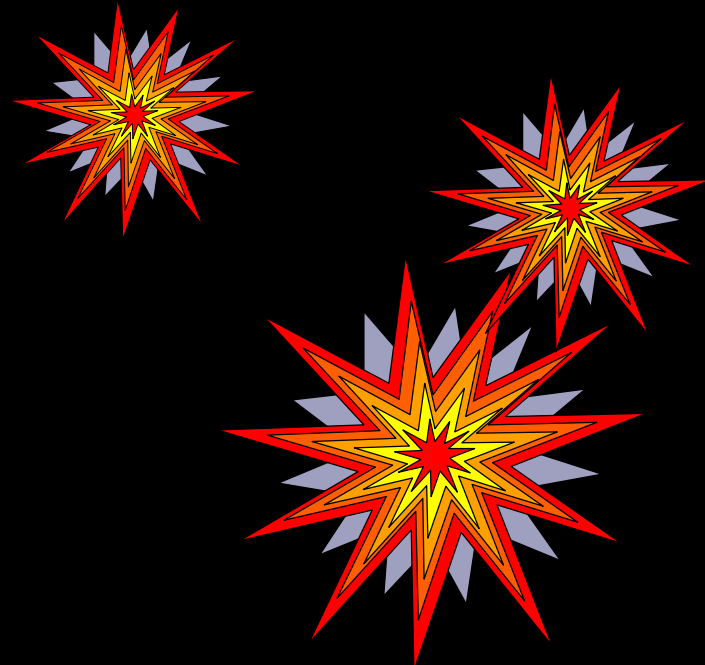

A decorative border consisting of a vertical sequence of colorful diagonal stripes on both the left and right sides of the slide. The stripes are in the following order from top to bottom: red, blue, teal, orange, yellow, red, blue, teal, orange, yellow, red, blue, teal, orange.

“EETAOW! The Next Chapter”
from
New Tribes Mission



Part Three: Resources

- Printed Reference Material
- Pictures
- Jesus Film
- Cassettes
- Time-line
- Conferences

Visual Literacy

- Color
- Flow
- Reproducibility
- Flannelgraph vs. Pictures
- Wording
- Biblical Accuracy

Media Resources

- Networking--Addresses & what to use
- Learning the Methodology
 - no “cookbook” recipe nor 1 size fits all
- The Yao Project--media case study

Multiple Media Effectiveness

The Yao Project

-8	No Awareness of the Gospel
-7	
-6	Knowledge of Gospel Basics
-5	Understanding Gospel Implications
-4	Positive Attitude Toward Becoming a Christian
-3	Problem Recognition
-2	
-1	
0	Change of Allegiance
+1	Re-evaluation
+2	Incorporation into Church
+3	Spiritually Reproducing

Multiple Media Effectiveness

The Yao Project

SPIRITUAL DECISION SCALE

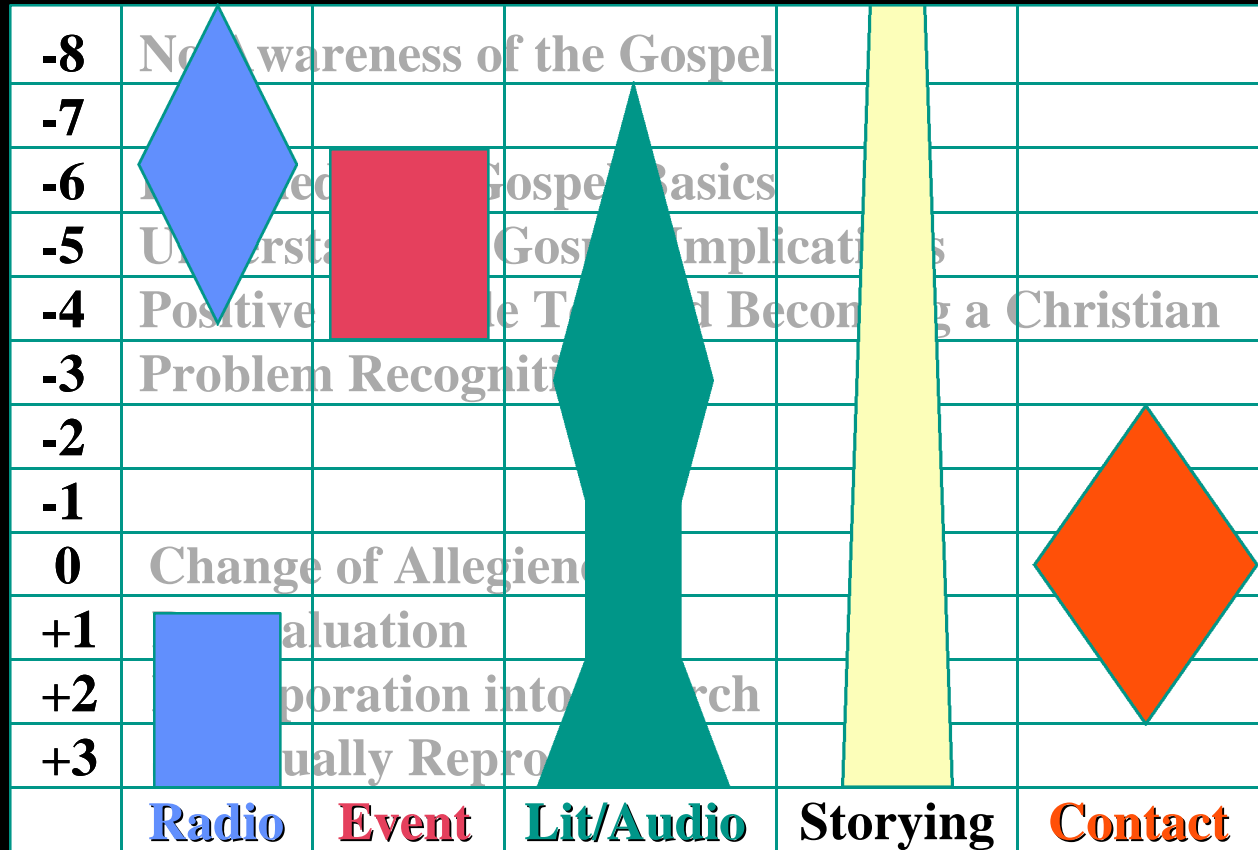

Multiple Media Effectiveness

The Yao Project

SPIRITUAL
DECISION
SCALE

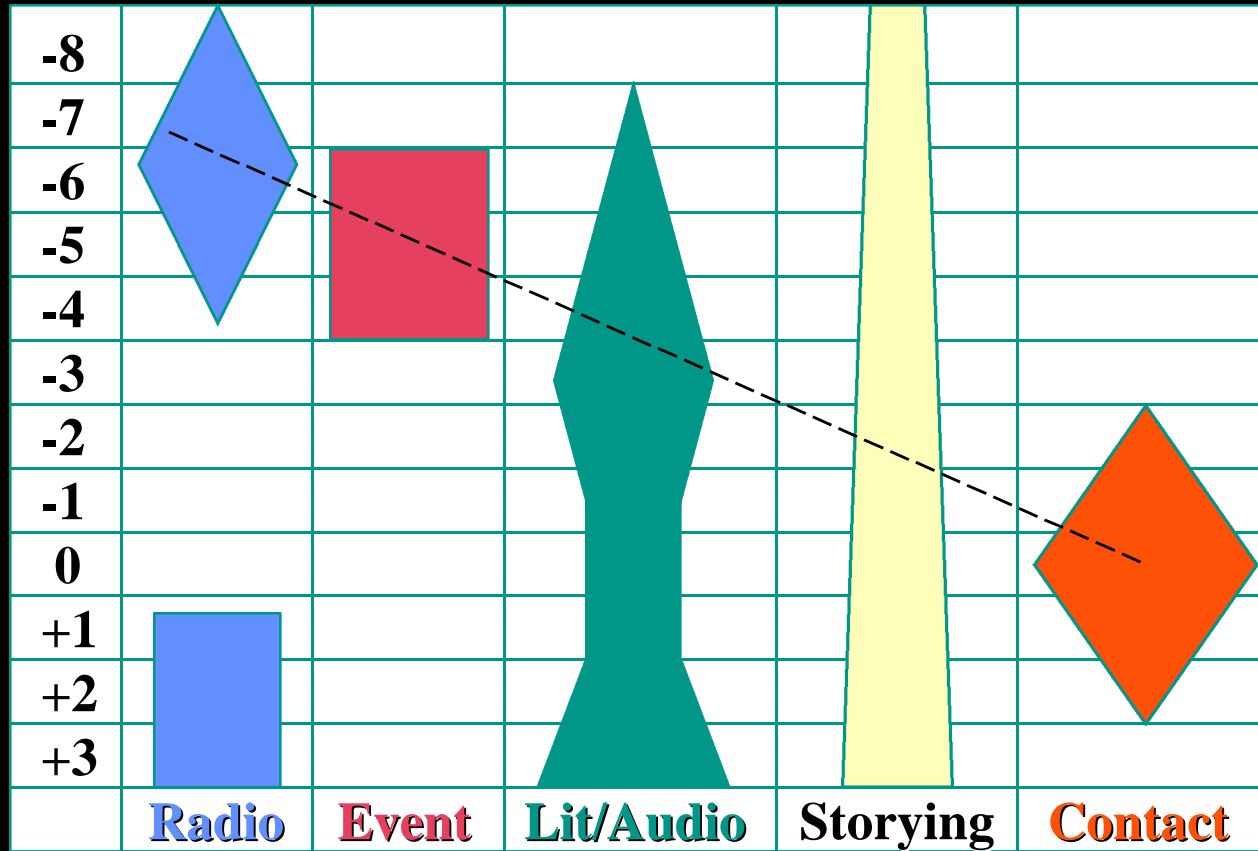



Chronological Storying of the Bible

Thank you!

